

SERIES 555 SPECIFICATIONS



Description

The Series 555 is a sophisticated programmable control platform optimized for use in industrial applications. The controller can currently be purchased with a 128 x 128 graphic Liquid Crystal Display (LCD). In the future, you will be able to purchase a version with a 4 x 20 Vacuum Fluorescent Display (VFD). The VFD version, model number Series 555V, has a wider temperature range while the LCD version, model number Series 555, allows for more creative screen displays.

Inputs

- 16 – Optically Isolated Digital Inputs.
- 10 – 12 bit analog inputs configurable for 0-5 VDC, End of Line 4-20 mA, and electric gauge sender. The sender configuration can measure up to 1250 ohms with 4 mA of current and 250 ohms with 20 mA of current. Loop power must be above 10 VDC.
- 1 – Battery voltage monitor input.
- 1 – Frequency Pickup for engine speed monitoring. (1.5VAC RMS to 140 VAC RMS)

Outputs

- 14 – Transistor Outputs - sinking (ground out) - outputs are rated 140 mA @ 85 °C with all outputs ON. Each of these outputs has a 300 mA current limit /

over-temperature shutoff protection feature. NOTE: If more current is required, the unit can be programmed to turn on two outputs simultaneously and the current capability will be doubled. Just hook your load to both outputs.

- 2 – Dedicated auto throttle outputs – sinking (ground out) – 500 ma @ 85 °C. These outputs have a 2 Amp current limit / over-temperature shutoff protection feature.
- 2 – B+ outputs – 2 Amps @ 85 °C. These outputs have a 5 Amp current limit / over-temperature shutoff protection feature.
- 1 – TATTLETALE® output – 125 mA @ 85 °C. This output does NOT have a current limit / over-temperature shutoff protection feature.
- 2 – 12-bit 0-24 ma analog outputs.
- 2 – Pulse Width Modulation Outputs – 125 mA @ 85 °C. These outputs do NOT have a current limit / over-temperature shutoff protection feature.

Communication

- 2 – RS-485 Communication ports. Connection is made via modular RJ45 Jack. There are two jacks for simple connection to a chain of devices including the Murphy Comm Series of I/O modules. If the SERIES 555 is at one end of an RS-485 chain, it must have a terminating resistor installed in the second jack. This resistor module is available from Murphy as part number 65267485TERMM.
- 2 – RS-232 Communication ports. Connection is made via modular DB-9 connectors.
- 1 – CAN Port using J1939 Communication Protocol.

Temperature Rating

- Operating** -20 to +70 °C (LCD Version)
- Storage** -30 to +70 °C (LCD Version)
- Operating** -40 to +85 °C (VFD Version)
- Storage** -40 to +85 °C (VFD Version)

Power Input Voltage

9 to 28 VDC

User Interface

The LCD version has the Murphy standard 3-button interface, which utilizes UP, DOWN, and SELECT keys for moving through the screens and setup numbers. It also has 3 “soft keys” that are tied to specific screen labels. These labels are under software control. When the user presses a “soft key” it will perform the function specified on the label.

The Series 555V offers a complete numeric keypad for direct entry of set-point values and S-number configuration.

Series 555 Port Descriptions

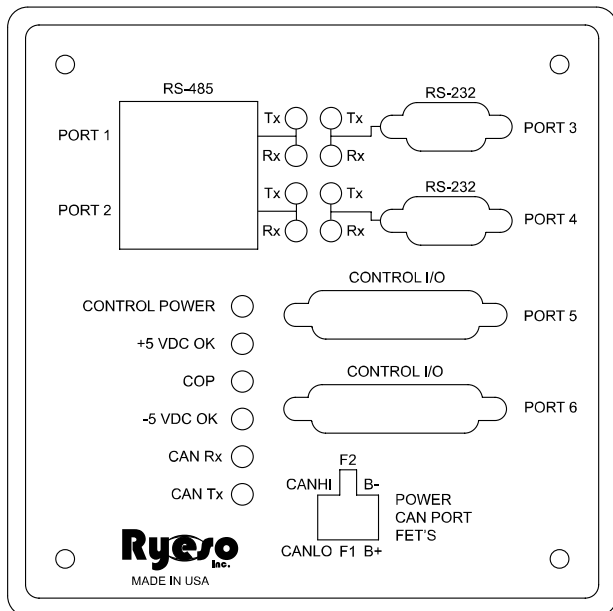

Series 555 Back View

The Series 555 has 6 ports and one power plug. The port descriptions follow:

Port 1 RS485 (2 – RJ45 Jacks)

2 wire RS-485 communications. The table shows the pin connections. Note: Both Jacks are wired the same and pins 4 and 5 on each jack are wired together.

Pin #	Description
1	Not Connected
2	Not Connected
3	Not Connected
4	RS-485 +
5	RS-485 -
6	Not Connected
7	Not Connected
8	Not Connected

Port 2 RS485 (2 – RJ45 Jacks)

2 wire RS-485 communications. The table shows the pin connections. Note: Both Jacks are wired the same and pins 4 and 5 on each jack are wired together.

Pin #	Description
1	Not Connected
2	Not Connected
3	Not Connected
4	RS-485 +
5	RS-485 -
6	Not Connected
7	Not Connected
8	Not Connected

Port 3 RS232 (DB-9 – Female)

DB9 connector. The following table shows the pin connections. * Pins 4 and 7 are internally connected. Both functions are not available simultaneously.

Pin	Description
1	Carrier Detect
2	Receive Data
3	Transmit Data
4	Data Terminal Ready*
5	Signal Ground
6	No Connect
7	Request To Send*
8	Clear To Send
9	No Connect

Port 4 RS232 (DB-9 – Male)

DB9 connector. The following table shows the pin connections. * Pins 4 and 7 are internally connected. Both functions are not available simultaneously.

Pin	Description
1	Carrier Detect
2	Receive Data
3	Transmit Data
4	Data Terminal Ready*
5	Signal Ground
6	No Connect
7	Request To Send*
8	Clear To Send
9	No Connect

Port 5 Control I/O (DB-25 – Female)

This is the first of two control I/O ports. Analog and digital inputs and outputs are connected to this port. The following table describes the connections:

Pin	Description
1	Analog Input 1
2	Analog Input 2
3	Analog Input 3

4	Digital Input 1
5	Digital Input 2
6	Digital Input 3
7	Digital Input 4
8	Digital Output 3
9	Digital Output 4
10	Digital Output 5
11	Pulse Width Modulated Output 1 (Output 19)
12	Throttle Increase (Output 17)
13	Throttle Decrease (Output 18)
14	Analog Input 4
15	Analog Input 5
16	Digital Input 5
17	Digital Input 6
18	Digital Input 7
19	Digital Input 8
20	Digital Output 6
21	Digital Output 7
22	Digital Output 8
23	No Connection
24	Controller Reset or TATTLETALE® Output
25	Frequency Input

20	Digital Output 13
21	Digital Output 14
22	Digital Output 15
23	Digital Output 16
24	Pulse Width Modulated Output 2 (Output 20)
25	Analog Loop Power

Power Power Connector (Molex – 4 Pin)
This is the control power connector. The following table describes the connections:

Pin	Description
1	Battery (+) 9 to 28 VDC
2	Digital Output 1 (B+)
3	CAN LO
4	Battery (-)
5	Digital Output 2 (B+)
6	CAN HI

Accessory Modules and Part Numbers for Use with Series 555

Terminating Resistor Module



Part Number: 65267485TERMM

Function: Provides the RS-485 terminating resistor to the last module in the group.

RJ45 Patch Cables



Part Number:

- 1 – Foot: 65267CABLE1
- 2 – Foot: 65267CABLE2
- 4 – Foot: 65267CABLE4
- 6 – Foot: 65267CABLE6

Function: Provides an interconnection between control head and multiple Comm Series modules. The cable is available in various lengths.

Port 6 Control I/O (DB-25 – Female)
This is the second of two control I/O ports. Analog and digital inputs and outputs are connected to this port. The following table describes the connections:

Pin	Description
1	Analog Input 6
2	Analog Input 7
3	Analog Input 8
4	Digital Input 9
5	Digital Input 10
6	Digital Input 11
7	Digital Input 12
8	Digital Output 9
9	Digital Output 10
10	Digital Output 11
11	Digital Output 12
12	Analog Output 1
13	Analog Output 2
14	Analog Input 9
15	Analog Input 10
16	Digital Input 13
17	Digital Input 14
18	Digital Input 15
19	Digital Input 16